



Enagic[®]
INDEPENDENT
DISTRIBUTOR

World's healthiest Water Kangen Water

Kangen Means "Return to Origin"



*Change your water...
Change your Life!*

- **Anti-Oxidant**

Helps us fight oxidative stress

- **Alkalinization**

Helps us fight acidic stress

- **Micro-Cluster**

Helps us fight dehydrating stress

**49 YEARS
JAPANESE**

**COMPANY
CHANGING LIVES**



Return to Origin

+91 999 035 8272

+91 981 823 6818

www.aquamiracle.org

Info@aquamiracle.org

elitebrains02@gmail.com

You are born Alkaline & die Acidic

Our body is **70% Water**

Brain 74.5% water

Blood 83% water

Muscles 76% water

Liver 86% water

Heart 79% water

Kidneys 83% water

Lungs 80% water

Fat 20% water

Skin 70% water

Bones 22% water

Joints 83% water

Connective Tissue
60% water

Eyes
95% water

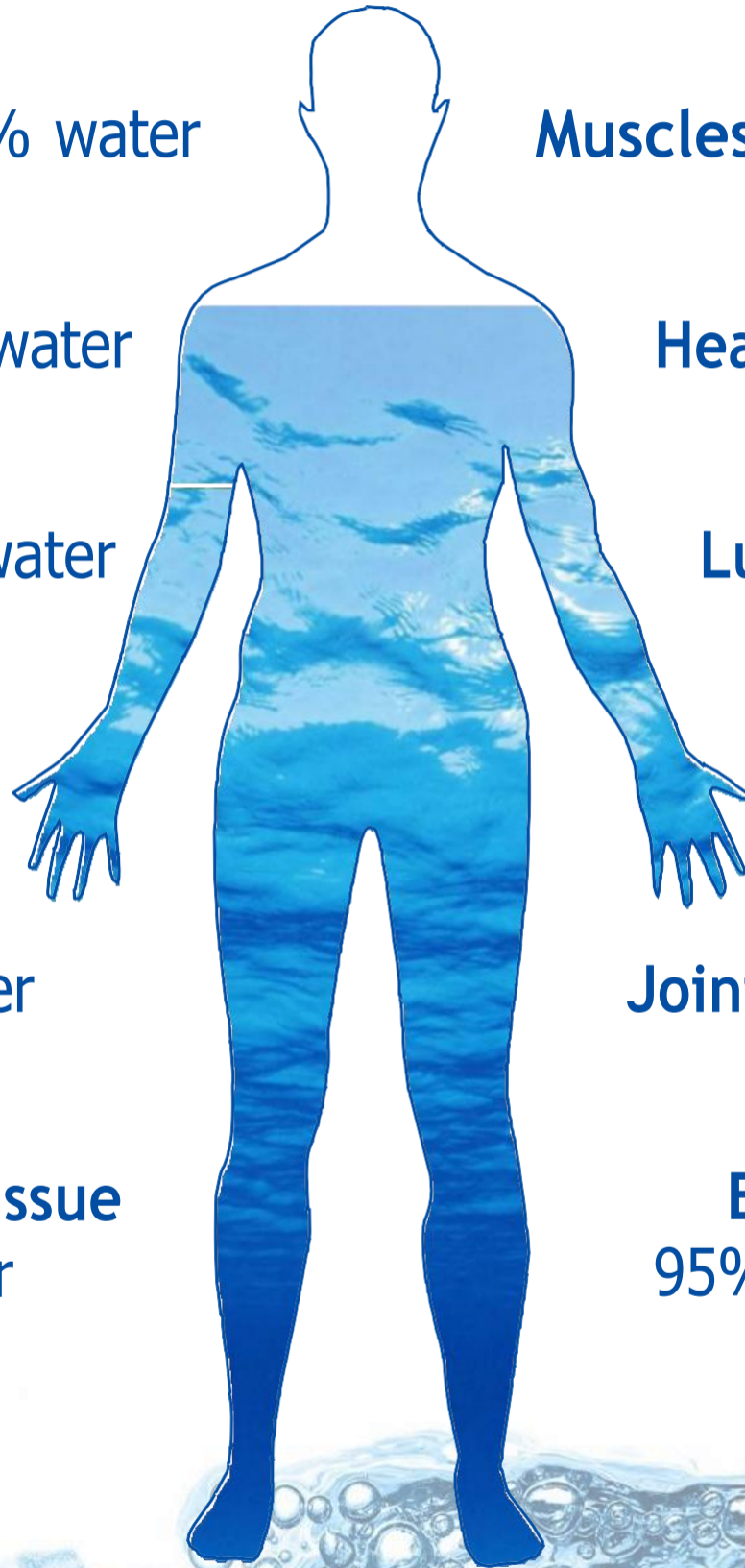

www.aquamiracle.org

do you know, who you are ? Actually

+91 999 035 8272

+91 981 823 6818

Info@aquamiracle.org

elitebrains02@gmail.com

Healing is voltage, recharge your body with Kangen Water

KANGEN WATER IONIZER

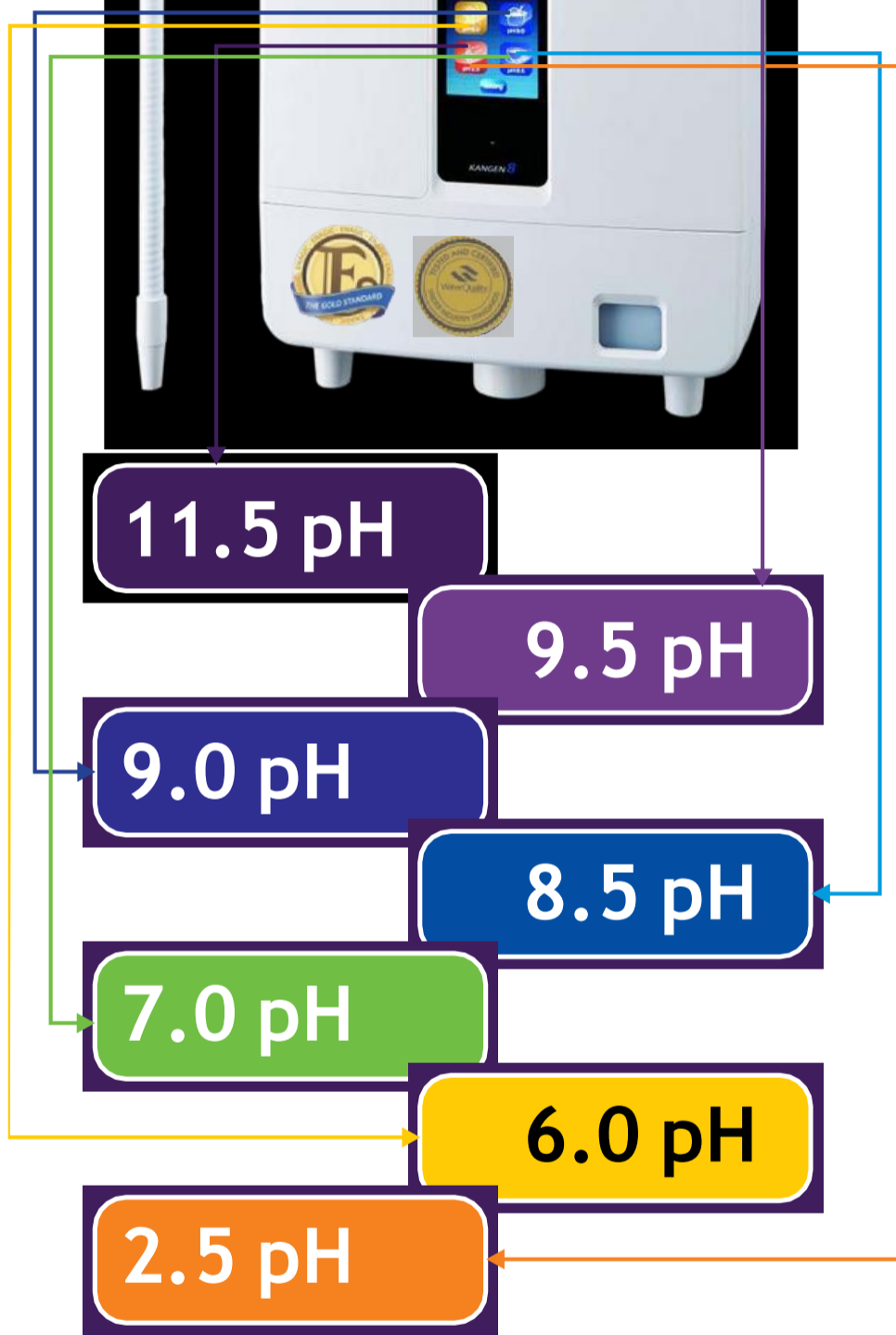

- 8.5
9.5
pH**

Drinking and Cooking...
anti aging
- 7.0
pH**

Baby Formula
& Medication
- 4.5
6.0
pH**

Tonner & Astringent
Hair Care, Groom Pets.
Clean Mirrors & Glass.
House Cleaning - Floor
Tiles. Great For Plants.
- 2.5
pH**

Disinfectant : Electrolyzed
Hypochlorous Acid
Kills virus and
bacteria. Sterilizing &
Sanitizing. Skin
Rashes.
- 11.5
pH**

Emulsifier
Removes Pesticides from
fruits and vegetables.
Cleans greasy pots & Pans.
Laundry Detergent.

www.aquamiracle.org

Info@aquamiracle.org
elitebrains02@gmail.com

+91 999 035 8272
+91 981 823 6818

A small life style change can have major health benefits

UNIQUE PROPERTIES OF KANGEN WATER

1. POWERFUL ANTI-OXIDANT

Kangen water provides extra electrons that neutralize destructive free radicals circulating throughout the body. Kangen water carries a high negative ORP (Oxidation-Reduction Potential) when it is first produced, making it a potent anti-oxidant.

The higher the negative number the greater the potential to reduce the levels of Oxidation in the body.

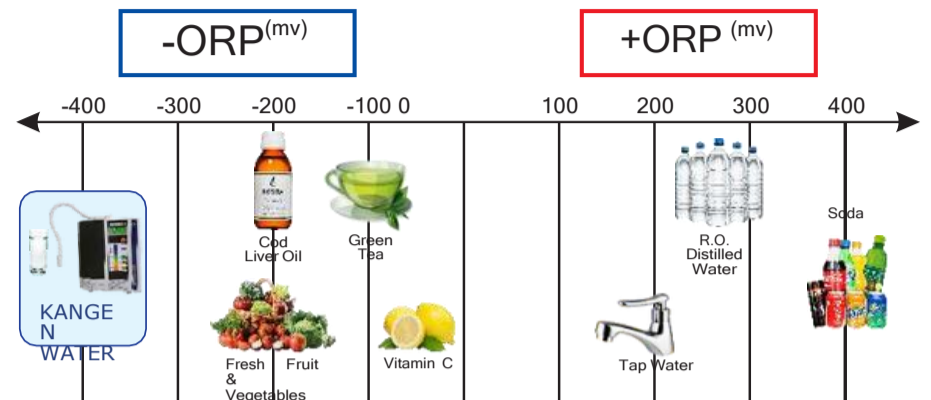

2. ALKALINITY

Kangen water raised tap water pH by ionizing or splitting the water molecules (H₂O resulting in the ions H⁺ (hydrogen with a positive electrical charge), and OH⁻ (hydrogen with negative electric charge), as well as ionic alkaline minerals.

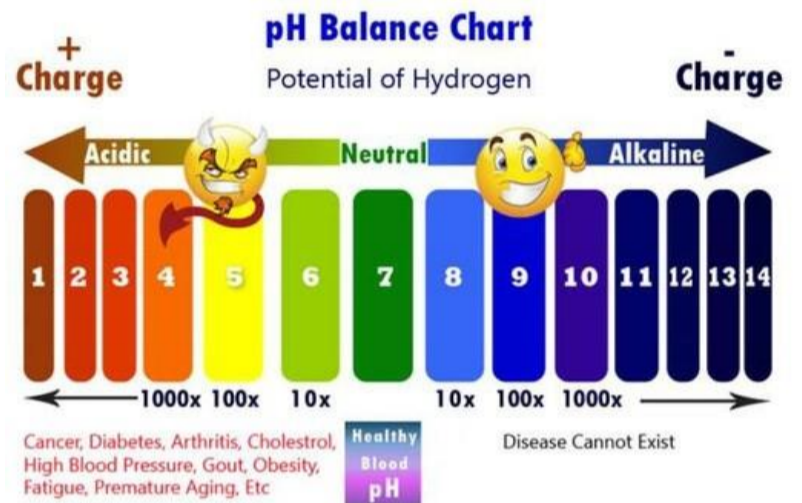

3. MICRO CLUSTERED

The process of ionization reduces the size of the water cluster by two thirds and creates a hexagonal shape. Similar, hexagonal water clusters easily hydrate the cells, enhancing waste removal.

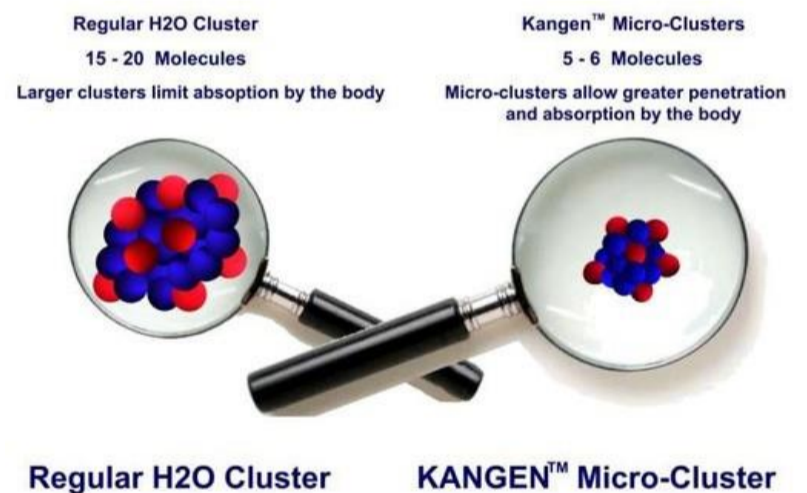

4. HYDROGEN ENRICHED WATER

The molecule of hydrogen water is small enough to penetrate into cells deeply. The utmost thing is hydrogen water can neutralize ROS (Reactive Oxygen Species) which are notorious for destroying normal cells or distorting DNAs. Besides, you can also enjoy helpful minerals dissolved in hydrogen water.



HEALING IS VOLTAGE !

How to Recharge Your Body-Battery

Every cell in the body is designed to run at -20 to -25 millivolts. To heal, we must make new cells. To make a new cell requires -50 millivolts. Chronic disease occurs when voltage drops below -20 and/or you cannot achieve -50 millivolts to make new cells. Thus chronic disease is always defined by having low voltage. This book tells you how to measure your voltage in each organ, how to correct it, and how to determine why your voltage dropped enough to allow you to get sick.

Healing Is Voltage : The Handbook, Jerry Tennant, MD, MD(H), PSc., D

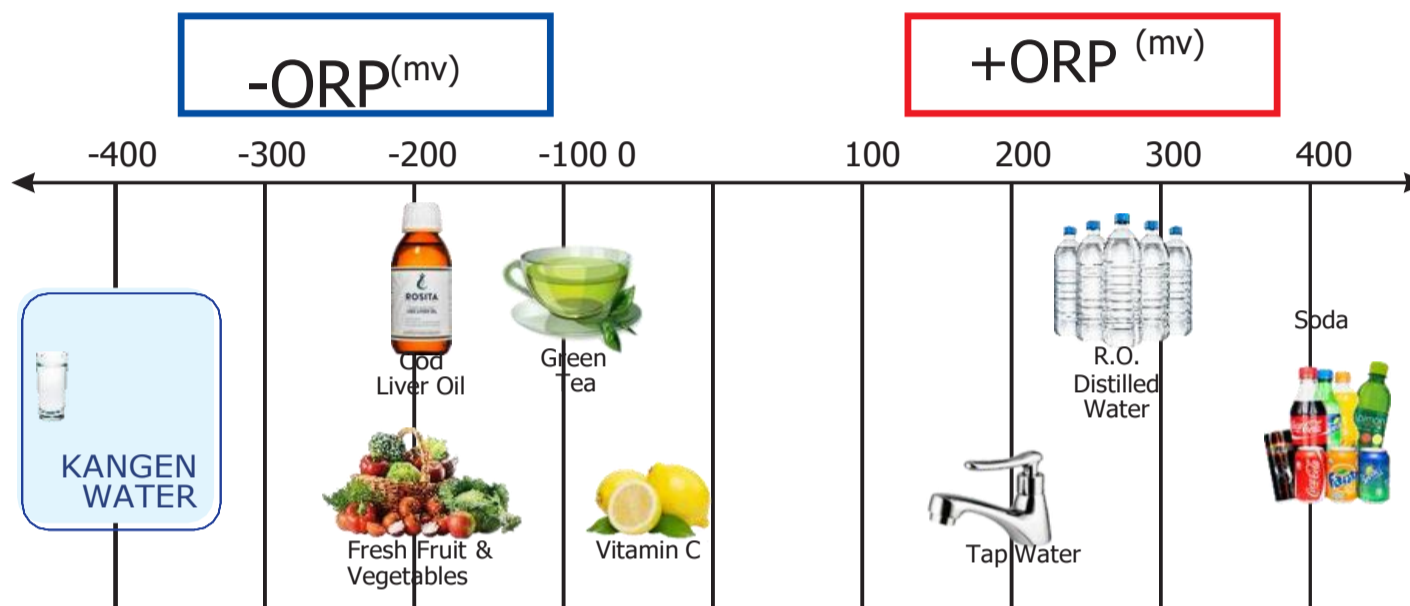

Cell Voltage	Cell pH	Body Changes
-50	7.88	Make new cells
-45	7.79	
-40	7.70	
-35	7.61	Normal for kids
-30	7.53	
-25	7.44	Normal for adults
-20	7.35	
-15	7.26	Tire
-10	7.18	d
-5	7.09	Sick
0	7.00	Cell change polarity
+5	6.91	
+10	6.83	
+20	6.65	
+30	6.48	Cancer occurs

DR OTTO HEINRICH WARBURG

Discovered the real cause of cancer in 1923 and received the Nobel Prize for Physiology in 1931

In his work the metabolism of tumors he demonstrated that all forms of cancer are characterized by two basic conditions :

ACIDOSIS and HYPOXIA (lack of oxygen).

Cancerous tissues are Acidic, Healthy tissues are Alkaline.

"Deprive a cell 35% of its oxygen for 48 hours and it may become cancerous."



pH Scale



	pH (hydrogen)	Examples :
n 1.0	10,000,000 x more Acidic	Strong - Lead Acid Battery
1.0	1,000,000 x more Acidic	Strong - Sulphuric Acid
2.0	100,000 x more Acidic	Strong - Acidic Chemicals
3.0	10,000 x more Acidic	Tea, Soda, Carbonated Beve
4.0	1,000 x more Acidic	Juices, Beer Energy Drinks
5.0	100 x more Acidic	Coffee
6.0	10 x more Acidic	Bottled Waters
6.5	4 x more Acidic	Milk
7.0	Neutral	Tap Water (Average)
7.4	3 x more Alkaline 10 x more Alkaline	Healthy Blood Mild Kangen Water
8.0 9.0	100 x more Alkaline	Kangen Waters (9.0 and 9.5)
10.0	1,000 x more Alkaline	Milk of Magnesia
11.0	10,000 x more Alkaline	Ammonia
12.0	100,000 x more Alkaline	Bleach
13.0	1,000,000 x more Alkaline	Household Lye
14.0	10,000,000 x more Alkaline	Strong Alkaline Chemicals



**TEAM
AQUA MIRACLE**
EMPOWERING LIVES THROUGH HEALING WATER



Leveluk Super 501

3,97,000

(Shipping charge extra as per zone)

Enagic's Most Powerful Model

The Super501 is the highest quality water ionizer for heavy home use, featuring a built-in electrolysis enhancer tank and 7 and 5 electrode plates. If you need safe, clean alkaline water to hydrate your growing family or business, the Super501 is the perfect solution! This highly productive machine also generates 5 different types of water for numerous uses around your home or business. With an easy to use LCD screen and clear voice prompts, the Super501 is accessible and simple to operate.

Product Specifications

Electrode plates	: 7 & 5
Plate size	: 135 x 75 (mm)
Negative ORP	: -800 (mV)
pH Range	: 2.5 – 11.5
Generates	: 5 water types
Wattage	: 200 (W)
Total weight	: 10.1 (kg)
Dimensions WHD	: 352 x 384 x 250 (mm)
Production rate	: Kangen Water® : 4.9 – 7.9 (l/min) Acidic Water : 1.9 – 3.0 (l/min) Strong Acidic Water : 1.1 – 3.0(l/min) Fully automatic,
Ease of Use	: very simple to operate
Languages	: 1
Warranty	: 3 (years)

+91 999 035 8272

+91 981 823 6818

Info@aquamiracle.org

elitebrains02@gmail.com

www.aquamiracle.org

You are not old, you are dehydrated



TEAM
AQUA MIRACLE
EMPOWERING LIVES THROUGH HEALING WATER

Leveluk K8

3,43,000

(Shipping charge extra as per zone)

The Mighty 8-Plate Anti-Oxidizer

The Kangen 8 is Enagic most powerful antioxidant machine featuring 8 platinum-dipped titanium plates for improved water ionization and increased antioxidant production potential. Enjoy this Kangen Water machine in virtually any country, thanks to its worldwide multi-voltage power supply and interchangeable plug capability (sold separately). If you're looking for a powerful, versatile, feature-loaded machine, the Kangen 8 is for you.

- Speaks EIGHT Languages! 8 Language Display and Audio in Japanese, English, French, German, Chinese, Italian, Spanish and Portuguese

Product Specifications

Electrode plates	: 8
Plate size	: 135 x 75 (mm)
Negative ORP	: -850 (mV)
pH Range	: 2.5 – 11.5
Generates	: 5 water types
Wattage	: 230 (W)
Total weight	: 5 (kg)
Dimensions WHD	: 345 x 279 x 147 (mm)
Production rate	: Kangen Water ® : 4.5 – 7.6 (l/min) Acidic Water : 1.5 – 2.6 (l/min) Strong Acidic Water : 0.6 – 1.1(l/min) Fully automatic,
Ease of Use	: very simple to operate
Languages	: 8
Warranty	: 5 (years)

+91 999 035 8272
+91 981 823 6818

Info@aquamiracle.org
elitebrains02@gmail.com

www.aquamiracle.org

You are not sick, you are thirsty, don't treat thirst with medication



**TEAM
AQUA MIRACLE**
EMPOWERING LIVES THROUGH HEALING WATER



Leveluk SD501 (Platinum)

2,97,000

(Shipping charge extra as per zone)



Introducing the BRAND NEW 5-Language SD501 Platinum!

The new Leveluk SD501 PLATINUM features a revamped modern design geared to match today more stylish kitchens. Same power and performance as the SD501 in an all new package! The industry-leading continuous ionized electrolysis water generator system, the SD501 PLATINUM is the finest machine in its class. With the strongest electrolysis chamber available, fully-equipped with a built-in electrolysis chamber, and featuring a large LCD panel and clear voice prompts, the SD501 PLATINUM is the leader of the pack.

The Multi-Language SD501 Platinum expertly speaks in 5 languages: English, German, French, Italian and Spanish!

Product Specifications

Electrode plates	:	7
Plate size	:	135 x 75 (mm)
Negative ORP	:	-800 (mV)
pH Range	:	2.5 – 11.5
Generates	:	5 water types
Wattage	:	230 (W)
Total weight	:	6.3 (kg)
Dimensions WHD	:	264 x 338 x 171 (mm)
Production rate	:	Kangen Water® : 4.5 – 7.6 (l/min) Acidic Water : 1.5 – 2.6 (l/min) Strong Acidic Water : 0.6 – 1.1 (l/min) Fully automatic,
Ease of Use	:	very simple to operate
Languages	:	5
Warranty	:	5 (years)

+91 999 035 8272
+91 981 823 6818

Info@aquamiracle.org
elitebrains02@gmail.com

www.aquamiracle.org

The definitive guide to the world's healthiest substance

Leveluk SD501

2,77,000

(Shipping charge extra as per zone)



The Ultimate Home Use Model

The SD501 is the finest machine in its class, with the highest quality built-in electrolysis chamber on the market. This Kangen Water® filtration machine generates a continuous stream of 5 types of water. Generates: Strong Kangen Water, Kangen Water®, Neutral Water, Beauty Water, and Strong Acidic Water.

The SD501 is Enagic's "Flagship" model because it provides additional stable oxygen, better micro-clustering, and higher negative ORP levels. Like all 501 models, the SD501 uses innovative electrolysis technology with 7 platinum-coated 99.97% pure titanium electrode plates.

Product Specifications

Electrode plates	: 7
Plate size	: 135 x 75 (mm)
Negative ORP	: -800 (mV)
pH Range	: 2.5 – 11.5
Generates	: 5 water types
Wattage	: 230 (W)
Total weight	: 5 (kg)
Dimensions WHD	: 264 x 338 x 171 (mm)
Production rate	: Kangen Water® : 4.5 – 7.6 (l/min) Acidic Water : 1.5 – 2.6 (l/min) Strong Acidic Water : 0.6 – 1.1 (l/min) Fully automatic,
Ease of Use	: very simple to operate
Languages	: 1
Warranty	: 5 (years)

+91 999 035 8272

+91 981 823 6818

Info@aquamiracle.org

elitebrains02@gmail.com



Anespa DX
2,00,000
(Shipping charge extra as per zone)

Mineral ION Water Spa

Treat yourself to a soothing hot spring experience with the ANESPA DX! With an abundant flow of mineralized water and a relaxing massage shower head, your bathroom can instantly turn into a calming hot spring oasis. Generates: Mineral ion water for your bath or shower.

Contains a blend of natural hot spring ingredients and minerals, giving you the feeling that you're enjoying a pleasant hot spring and taking advantage of the mineral ion water. Relax and enjoy!

Product Specifications

Electrode plates	::	N/A
Plate size	::	N/A
Generates	::	Mineral ion water for your bath or shower
pH Range	::	Same as tap water
Wattage	::	N/A
Total weight	:	2.5 (kg)
Dimensions W x Diameter		130 x 346 (mm)
Production rate		2.6 (l/min)
Ease of Use		Very simple to install and operate
Warranty		3 (years)
New features for DX model		Larger ceramic cartridge containing a greater amount of ceramic balls. New, redesigned base for a more efficient filter replacement process.

+91 999 035 8272

Info@aquamiracle.org

+91 981 823 6818

elitebrains02@gmail.com



**TEAM
AQUA MIRACLE**
EMPOWERING LIVES THROUGH HEALING WATER



Leveluk JR IV

2,18,000

(Shipping charge extra as per zone)

Echo Friendly Model

The JRIV has four solid electrode plates which reduce the energy consumption. Due to the solid platinum-coated titanium plates, this unit can still produce the strong acid and strong Kangen waters.

With just a touch of a button, you can have access to any of the 5 waters you choose. Periodically controlled by

Product Specifications

Electrode plates	: 4	
Plate size	: 135 x 75 (mm)	
Negative ORP	: -450 (mV)	
pH Range	: 2.5 – 11.5	
Generates	: 5 water types	
Wattage	: 120 (W)	
Total weight	: 5.3 (kg)	
Dimensions WHD	: 264 x 338 x 171	
Production rate	: (mm) Kangen	:: 3.0 – 4.9
	Water® Acidic	: (l/min) 0.2 –
	Water	1.9 (l/min) 0.3
Ease of Use	: Strong Acidic Water	– 0.7 (l/min)
Languages	: Fully automatic unit	
Warranty	: 1	
	3 (years)	

+91 999 035 8272

+91 981 823 6818

Info@aquamiracle.org

elitebrains02@gmail.com

www.aquamiracle.org

If bodies heal themselves, why am I still sick

WORLDS FIRST TUMERIC FOOD WRAPPED WITH KANGEN WATER® OKINAWA **Turmeric UKONΣ** SIGMA™
KANGEN **New**



coming soon



The Power of Ayurveda coming soon in India

INGREDIENTS



CURCUMIN

A free radical scavenger and antioxidant



NIACIN

Helps maintain healthy skin and promote healthy liver function



HEALTHY MINERALS

Such as calcium, potassium, magnesium, iron, zinc, manganese, phosphorus, and selenium



FLAXSEED OIL

Promotes healthy cardiovascular function and helps maintain healthy cholesterol levels



OLIVE OIL

Helps maintain healthy levels of low-density lipoprotein (LDL)



EVENING PRIMROSE OIL

May help maintain cholesterol and blood sugar levels



PERILLA OIL

Another free radical scavenger and antioxidant



TOCOTRIENOL

Also called "Super Vitamin E" with strong antioxidants

+91 999 035 8272 Info@aquamiracle.org

+91 981 823 6818 elitebrains02@gmail.com

SYMPTOMS OF ACIDIC NATURE OF BODY

Mild	Moderate	Severe
Acidity	Weight Gain	Atherosclerosis (Heart
Constipation	Migraine	Problems) Diabetes
Frequent Infections	Endometriosis	Osteoporosis
Body Odour	Insomnia	Obesity
Lack of Enthusiasm	Depression	Arthritis
Headache	Sinusitis	Ulcerative Colitis
Teeth Problem	Skin Diseases	Cancer
	Allergies	Psoriasis
		Kidney Failure

Make Health Your Priority

Before

Disease Makes It Your Priority

WHO IS ENAGIC?

In 1974 in Okinawa, Japan, Sony's trading operation, the precursor of Enagic, began operations. Ever since, Enagic commitment to high quality products, innovation and True Health philosophy has made it the leader of water ionizer generating systems, now distributed globally.

New offices continue to open worldwide as the company expands and reaches more and more people providing

healthy,
alkaline water and a way to improve their finances as well.

- A 49 years old Japanese company.
- The only water ionizer company to receive a GOLD seal award.
- The only company that has an ISO medical certificate.
- Has branches in 28 different countries.

Japan Hong Kong Singapore

Taiwan Korea Canada

Romania PHILIPPINES Malaysia

Indonesia Thailand Australia

USA Portugal Toronto

Mexico Brazil Germany

Italy France India

Dubai

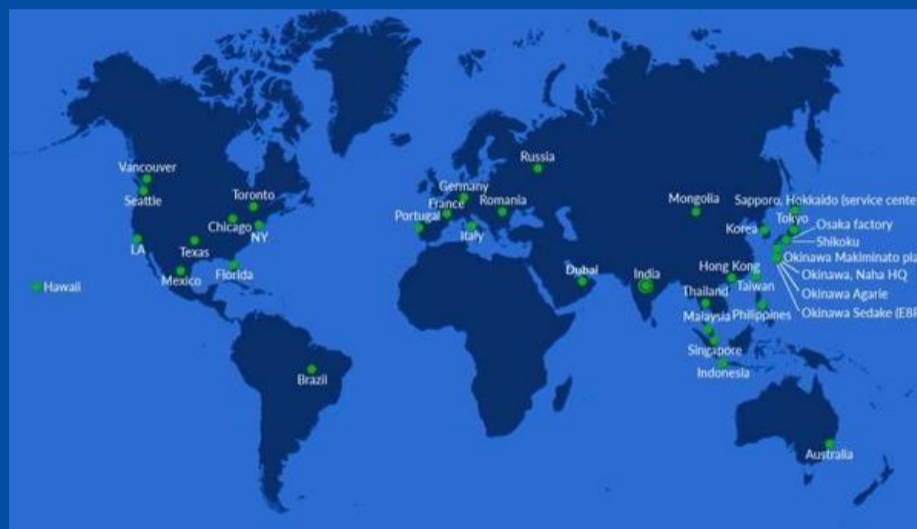

CERTIFICATIONS

Mechanism of Ionization

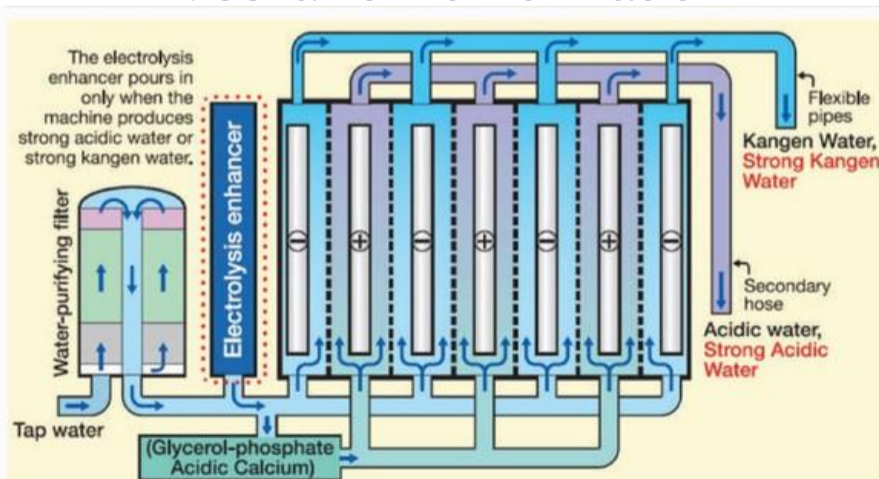

Info@aquamiracle.org

elitebrains02@gmail.com



www.aquamiracle.org

+91 999 035 8272

+91 981 823 6818